

**Ball & Roller Bearings:
Failures, Causes and Countermeasures**

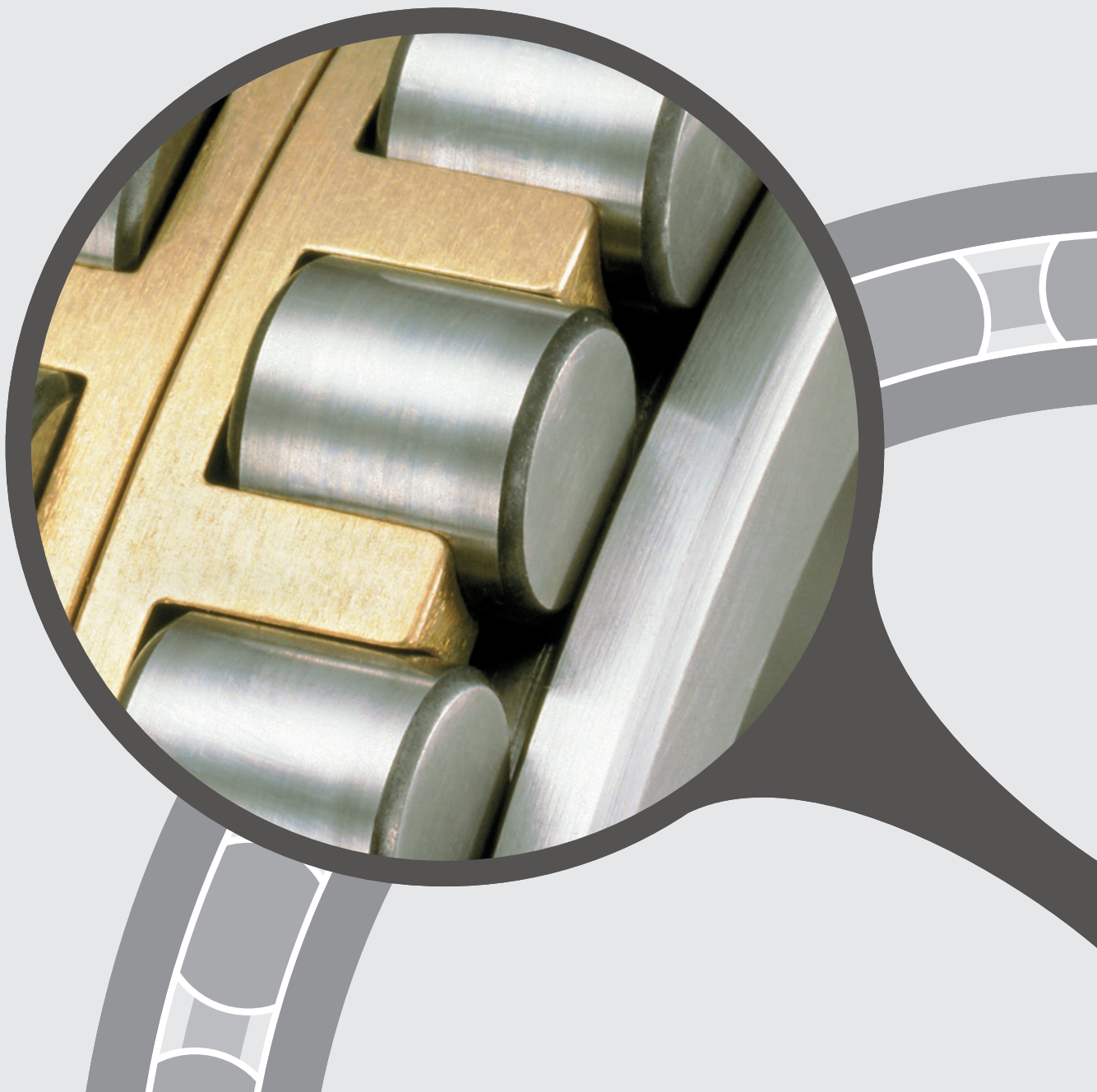

Contents

I . Bearing Fracture

1. Time of fracture occurrence and causes 1
2. Abnormal operations, their causes and countermeasures 2

II . Bearing Failure

1. Types of failure..... 3
2. Types of failure and parts in which they occur ... 3
3. Failures and causes 4

III . Failures, Causes and Countermeasures

- 1 Flaking, Pitting 5
- 2 Wear and Fretting 6
- 3 Cracks and Chips 7
- 4 Brinelling and Nicks 8
- 5 Scratches and Scuffing 9
- 6 Rust and Corrosion 10
- 7 Pear skin, Discoloration 11
- 8 Smearing 12
- 9 Creep 13
- 10 Electric pitting 14
- 11 Seizure 15
- 12 Failure of Cage..... 16

Rolling bearing: Description of each part

Deep groove ball bearing

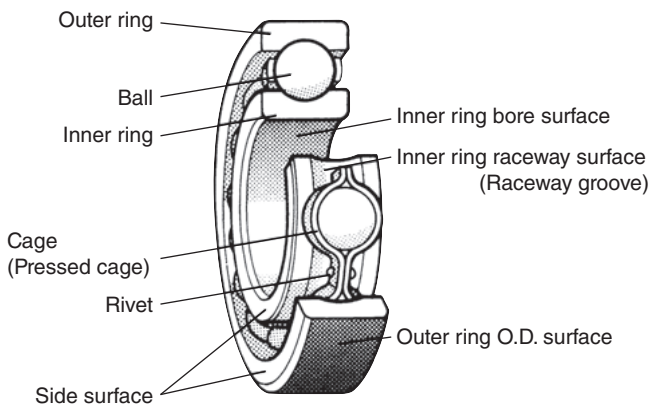

Tapered roller bearing

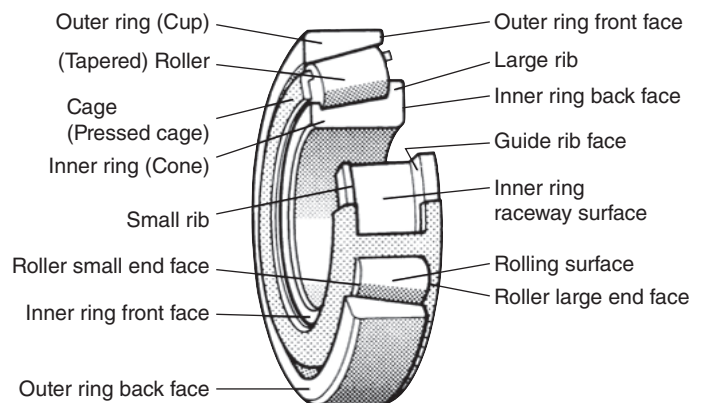

Cylindrical roller bearing

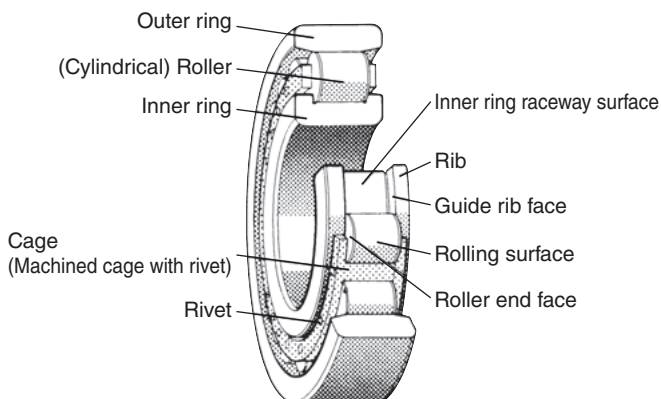

Spherical roller bearing

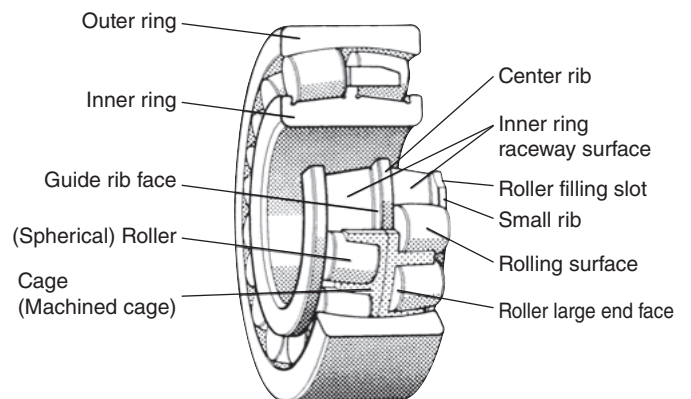

Introduction

Even when bearings are being used under ideal conditions, failures of bearings are caused by deterioration of the material due to rolling fatigue. Generally, the service life of bearings is expressed either as a period of time or as the total number of rotations before the occurrence of failures in the inner ring, outer ring or rolling element because of rolling fatigue, due to repeated stress.

Rolling bearings sometimes fracture earlier than expected. The following causes should be considered;

- ① Inappropriate use of bearings
- ② Faulty installation or improper processing
- ③ Improper lubricant, lubrication method or sealing device
- ④ Inappropriate speed and operating temperature
- ⑤ Contamination by foreign matter during installation
- ⑥ Abnormally heavy load

When bearing failure is found, even if it is insignificant, it is important to investigate the phenomenon to determine the causes. At this time, not only the bearing but also the shaft, housing, and lubricant used with the bearing should be comprehensively investigated, together with the bearing.

To judge the causes of failure, sufficient knowledge and experience in bearings and lubricants and a good understanding of the characteristics of the equipment are necessary. In addition, consideration of the installation conditions and operational process of the bearing is required.

[Reference] Rated service life of rolling bearing

$$L = \left(\frac{C_r}{P}\right)^p$$

$$L_h = \frac{10^6}{60n} \left(\frac{C_r}{P}\right)^p$$

L : Rated service life, 10^6 rotations
 L_h : Rated service life, h
 C_r : Basic dynamic load rating, N
 P : Dynamic equivalent load rating, N
 n : Rotational speed, min^{-1}
 p : 3Ball bearing,
 10/3Roller bearing

I . Bearing Fracture

1. Time of fracture occurrence and causes

For failure analysis, it is important to accurately determine the time a fracture occurs, because the possible causes of failure can be limited in according to the time of fracture occurrence.

For reference, time of fracture occurrence and related causes are categorized and listed in Table 1-1.

Table 1-1 Time of Breakage Occurrence and Causes

| Time of fracture occurrence | Causes | | | | | |
|--|-------------------------------|--|--|--------------------|--------------------------|---|
| | Inappropriate use of bearings | Faulty design of shaft, housing or other installation aspects or improper processing | Improper lubricant, lubrication method or sealing device | Defect in bearings | Mis-mounting of bearings | Defect in sealing device, contamination of water, dust or other foreign matters, or shortage of lubricant |
| (1) Fracture occurring immediately after bearings were mounted or within a short time after mounting | ○ | ○ | ○ | ○ | ○ | |
| (2) Fracture occurring immediately after overhaul | | | ○ | | ○ | |
| (3) Fracture occurring immediately after lubricant was supplied | | | ○ | | | |
| (4) Fracture occurring immediately after repair or removal of shaft, housing or other parts | | ○ | ○ | | ○ | |
| (5) Fracture occurring during normal operation | | | ○ | | ○ | ○ |

2. Abnormal operations, their causes and countermeasures

Causes and countermeasures of abnormal operations are categorized and listed in Table 1-2.

Table 1-2 Abnormal Operations, their Causes and Countermeasures

| Abnormal operation | | Causes | Countermeasures (supplementary countermeasures) |
|---|-------------------------------|---|---|
| Increase in temperature | | 1. Excessively tight bearing internal clearance | Replace with a new bearing. (Correct bearing internal clearance and interference.) |
| | | 2. Creep on bearing ring | Replace with a new bearing. (Correct interference.) |
| | | 3. Excessively heavy load | Remounting (Correct load by adjusting housing.) |
| | | 4. Improper centering in mounting | Remounting (Correct centering, or widen mounting clearance.) |
| | | 5. Defect in bearing | Replace with a new bearing. (Take proper countermeasures, after inspecting the causes.) |
| | | 6. Improper volume of lubricant | Correct lubricant volume. |
| | | 7. Improper lubricant | Change to proper lubricant. |
| | | 8. Improper lubrication method | Correct lubrication method by remounting or replacement with new parts. |
| | | 9. Oil seal - Excessive interference - Shortage of lubricant - Improper oil seal | Correct interference by installing new seal or changing seal type. Supply lubricant. Correct oil seal type or sealing method. |
| | | 10. Abnormal contact with labyrinth seal or other parts | Remounting or modify parts. |
| Excessively loud noise or foreign noise | Noise at uniform intervals | 1. Flaws including scratches, brinelling, etc. | Repair bearings or replace with new ones. (Care should be taken in handling bearings.) |
| | | 2. Electric pitting | Repair bearings or replace with new ones. (Prevent electricity from passing through bearings by modifying their design.) |
| | | 3. Cracking of inner or outer ring(s) | Replace with a new bearing. |
| | | 4. Flaking of raceway surface | Replace with a new bearing. |
| | | 5. Raceway surface roughened by foreign matter(s) | Repair bearings or replace with new ones. |
| | High-pitched metallic noise | 1. Excessively narrow internal clearance | Replace with a new bearing or widen internal clearance. |
| | | 2. Shortage of lubricant | Supply lubricant. |
| | | 3. Sliding of rolling element | Change to proper lubricant or decrease operational clearance. |
| | Noise at nonuniform intervals | 1. Contamination by foreign matter(s) | Change to proper lubricant. |
| | | 2. Contact with another rolling part | Remounting or modify parts. |
| | | 3. Flaw or flaking on rolling element | Replace with a new bearing. |
| | | 4. Wear of cage | Replace with a new bearing. |
| | Excessively high vibration | 1. Contamination by foreign matter(s) | Change to proper lubricant. |
| 2. Excessively wide clearance | | Remounting bearing or replace with a new one. | |
| 3. Flaw on raceway surface or rolling contact surface | | Replace with a new bearing. | |
| Excessively large rotational torque | 1. Improper mounting | Remounting (Widen internal clearance. Care should be taken with centering.) | |
| | 2. Improper sealing device | Remounting (Reduce interference of oil seal.) | |
| | 3. Improper lubricant | Decrease lubricant volume. (Care should be taken not to supply an excessive amount of lubricant.) | |

II . Bearing Failure

1. Types of failure

Defects in the appearance of bearings are referred to as bearing failures. Table 2-1 describes bearing failures, first assigning a general term to each type of failure, then adding more detailed classifications.

Table 2-1 Bearing Failure

| Bearing failures | | Main cause (reference) |
|------------------|--|------------------------|
| Failures | Failure details | |
| Rolling fatigue | Flaking, Pitting | Unavoidable |
| Wear | Wear, Fretting | Unavoidable |
| Fracture | Cracks, Chips | Improper handling |
| Flaw | Brinelling, Nicks, Scratches, Scuffing | Improper handling |
| Rust | Rust, Corrosion | Improper handling |
| Seizure | Seizure, Discoloration, Smearing | Improper lubrication |
| Creep | Creep | Improper fitting |
| Electric pitting | Electric pitting | Passage of electricity |

2. Types of failure and parts in which they occur

Table 2-2 describes bearing failures, parts where they occur, and standards for judging the failures.

Table 2-2 Bearing Failures, Parts in which they Occur, and Standards for Judging Failures

| Bearing failure | Bearing ring, Rolling element | | | Bearing ring | Cage | |
|------------------|--|---|----------|-------------------|-------------------------------------|---------|
| | • Raceway surface • Rolling surface | • Roller guide surface • Cage guide surface • Roller end face | • Others | • Fitting surface | • Pocket surface • Guide surface | • Rivet |
| Flaking, Pitting | × | — | — | — | — | — |
| Wear | ○ | ○ | ○ | ○ | ○ | × |
| Fretting | ○ | — | — | ○ | — | — |
| Cracks | × | × | × | × | × | × |
| Chips | × | × | ○ | × | × | × |
| Brinelling | ○ | ○ | ○ | ○ | — | — |
| Nicks | ○ | ○ | ○ | ○ | ○ | ○ |
| Scratches | ○ | ○ | ○ | ○ | ○ | ○ |
| Scuffing | ○ | ○ | ○ | ○ | — | — |
| Rust | ○ | ○ | ○ | ○ | ○ | ○ |
| Corrosion | ○ | ○ | ○ | ○ | ○ | ○ |
| Pear skin | ○ | — | — | — | — | — |
| Discoloration | ○ | ○ | ○ | ○ | — | — |
| Smearing | ○ | ○ | — | — | — | — |
| Creep | — | — | — | ○ | — | — |
| Electric pitting | ○ | ○ | — | — | ○ | — |
| Seizure | × | × | × | × | × | — |
| Failure of cage | — | — | — | — | ○ | × |

Notes) × : In principle, not reusable.

— : No failure of this part.

○ : Reusable in accordance with seriousness of failure, by repairing or meeting required conditions.

3. Failures and causes

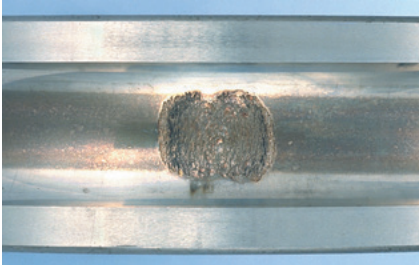

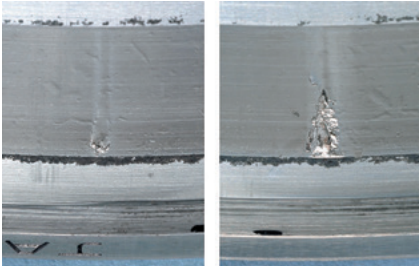
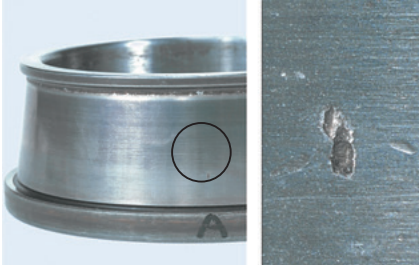

Table 2-3 describes failures and causes. For further detail, refer to Section " III . Failures, Causes and Countermeasures".

Table 2-3 Failures and Causes





| | Failure | Cause | Sketches of failures |
|---------------------|---|---|--|
| Flaking | Circumference on one side (Fig. 1) | Excessive axial load | <p>Fig.1 Flaking along circumference on one side. (Deep Groove Ball Bearing)</p> <p>Fig.2 Symmetrical flaking on each side. (Tapered Roller Bearing)</p> <p>Fig.3 Flaking in the form of an oblique line. (Deep Groove Ball Bearing)</p> <p>Fig.4 Scuffing on roller end face and guide rib face. (Cylindrical Roller Bearing)</p> <p>Fig.5 Cracks and/or chips on inner ring or roller. (Spherical Roller Bearing)</p> <p>Fig.6 False brinelling on inner ring. (Deep Groove Ball Bearing)</p> <p>Fluting Pitting</p> <p>Fig.7 Type of Electric pitting.</p> |
| | Symmetrical flaking on each side (Fig. 2) | Inclined mounting, or shaft or housing not in the shape of a circle | |
| | Flaking on one side or flaking in the form of an oblique line on raceway surface of bearing ring on fixed side (Fig. 3) | Distortion of shaft, insufficient centering, bearings not installed on shaft at the correct angle | |
| | Partial flaking on thrust bearing | Eccentric mounting | |
| | Flaking found on part only | Contamination by foreign matter(s), flaws, initial stage of flaking | |
| Scratches, Scuffing | Scuffing on roller end face and guide rib face (Fig. 4) | Excessive axial load, improper lubrication | |
| | Scratches on raceway surface | Grease of too high viscosity, excessive acceleration in starting | |
| | Scratches on raceway surface of thrust bearing | Sliding of rolling element caused by centrifugal force during rotation | |
| Cracks, Chips | Cracks or chips of rolling element (Fig. 5) | Improper bearing material, excessive impact too wide internal clearance of cylindrical roller bearing | |
| | Cracks or chips of inner ring or outer ring (Fig. 5) | Advanced stage of flaking, improper bearing material, interference too large, housing of inaccurate design | |
| | Cracks, chips of rib (Fig. 5) | Impact in mounting, axial impact, load too heavy | |
| | Cracks, chips of cage | Improper lubricant or lubrication method, high speed operation, vibration impact too strong, advanced stage of wear | |
| Creep | Creep on inner/outer rings | Insufficient interference | |
| Wear | Wear on inner/outer rings | Sliding abrasion, bearing of insufficient hardness, contamination by foreign matter(s), shortage of lubricant, improper lubrication | |
| | Wear caused by creep | Creep | |
| | Wear on cage | Contamination by foreign matter(s), improper lubrication, inclined bearing | |
| Rust, Corrosion | Rust on inner ring bore surface or outer ring O.D. surface | Fretting, water, humidity | |
| | Rust covering whole bearing surface, corrosion | Defective washing oil or lubricant, water, humidity | |
| Others | False brinelling (Fig. 6) | Progressing stage of flaws caused by load from vibration when machine is not running. | |
| | Fluting on raceway surface or roller rolling surface (Fig. 7) | Passage of electricity | |
| | Discoloration | Heat generation, chemical action | |

III. Failures, Causes and Countermeasures





1 Flaking, Pitting

| | Phenomena, causes and countermeasures | Examples of failures |
|-----------------|---|--|
| Phenomena | <p>■ Flaking is a phenomena in which the bearing surface turns scaly and peels off due to contact load repeatedly received on the raceway and rolling surface during rotation.</p> <p>Occurrence of flaking indicates that the end of a bearing's service life is near.</p> <p>● Pitting is a phenomena in which small holes 0.1 mm in depth are generated on the raceway surface by rolling fatigue.</p> <p>※ Flaking and pitting are often found at an early stage. In this case, countermeasures should be taken, after examining the causes.</p> | <p>■ Flaking on inner ring of Deep Groove Ball Bearing</p>  <p>(A-6977)</p> <p>■ Flaking on inner ring of Cylindrical Roller Bearing</p>  <p>(A-7024)</p> |
| Causes | <p>Flaking and pitting occur early in a bearing's service life under the following conditions:</p> <ol style="list-style-type: none"> 1) During operation, bearing internal clearance becomes narrower than specified. 2) Bearing ring is mounted at an inclination by mistake. 3) Flaw is created during mounting, or brinelling, nicks, rust, etc. occur on the raceway surface or rolling surface. 4) Inaccurate shape of shaft or housing (imperfect circle, depressions on surface.) | <p>■ Flaking on outer ring of Double-Row Cylindrical Roller Bearing</p>  <p>(A-6466, 6473)</p> <p>■ Flaking on inner ring of Tapered Roller Bearing</p>  <p>(A-6644, 6645)</p> |
| Countermeasures | <p>■ Flaking</p> <ol style="list-style-type: none"> a) Use a bearing with heavier rated load. b) Check if abnormal load is being generated. c) Improve lubrication method to ensure better formation of lubricant film, by increasing the viscosity. d) When a failure is discovered at an early stage, the countermeasures described above should be taken, after investigating the causes. <p>● Pitting</p> <ol style="list-style-type: none"> a) Increase viscosity of lubricant to ensure better formation of lubricant film. <p>(Care should be taken because foreign matters appear similar to holes caused by brinelling or corrosion.)</p> | <p>■ Flaking on inner ring of Spherical Roller Bearing</p>  <p>(A-6476)</p> |

2 Wear and Fretting

| | Phenomena, causes and countermeasures | Examples of failures |
|-----------------|---|--|
| Phenomena | <p>■ Wear is caused mainly by sliding abrasion on parts including the roller end face and rib, cage pocket surface, cage, and the guide surface of the bearing ring. Wear due to contamination by foreign matter and corrosion occurs not only to the sliding surface but also to the rolling surface.</p> <p>● Fretting is a phenomena which occurs when slight sliding is repeatedly caused on the contact surface. On the fitting surface, fretting corrosion occurs, generating a rust like powder.</p> <p>▲ If bearings receive a vibration load when they stop or operate, slight sliding occurs in the section between the rolling element and bearing ring due to elastic distortion. False brinelling, a flaw similar to brinelling, is generated by this condition.</p> | <p>■ Wear on roller and face of Cylindrical Roller Bearing</p>  <p>(A-4718)</p> <p>■ Wear on outer ring raceway surface of Double-Row Cylindrical Roller Bearing</p>  <p>(A-6714)</p> |
| Causes | <p>■ Wear</p> <ol style="list-style-type: none"> 1) Improper lubricant or shortage of lubricant. 2) Contamination by foreign matter(s). <p>● Fretting</p> <ol style="list-style-type: none"> 1) Vibration load. 2) Slight vibration on fitting surface caused by load. | <p>● Fretting on inner ring bore surface of Tapered Roller Bearing</p>  <p>(A-6649)</p> <p>● Fretting on outer ring O.D. surface of Deep Groove Ball Bearing Vertical fretting at symmetric positions 180° apart.</p>  <p>(A-6735)</p> |
| Countermeasures | <p>■ Wear</p> <ol style="list-style-type: none"> a) Review and improvement of lubricant and lubrication method. b) Filtering of oil. c) Improvement of sealing. <p>● Fretting</p> <ol style="list-style-type: none"> a) Investigation and countermeasures for the source of vibration. b) Investigation and increase of interference. c) Enhancement of shaft rigidity. | <p>▲ False brinelling on inner ring raceway surface of Deep Groove Ball Bearing</p>  <p>(A-7278)</p> |



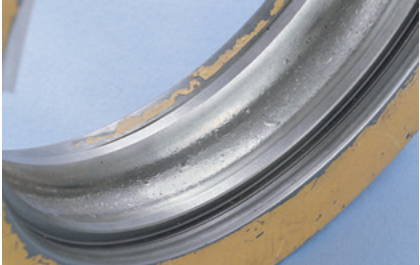
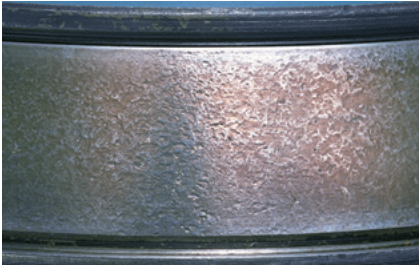

3 Cracks and Chips

| Phenomena, causes and countermeasures | | Examples of failures |
|---------------------------------------|--|--|
| Phenomena | <p>■ Cracks include slight cracks, splitting and fracture.</p> <p>● Chips are a type of failure occurring at a certain part of a bearing ring rib or corner of a roller.</p> | <p>■ Crack and chip in a Spherical Roller Bearing</p>  <p>(A-6395)</p> <p>■ Crack on outer ring of Four-Point Contact Ball Bearing Crack starting from key groove on O.D. surface.</p>  <p>(A-6625)</p> <p>■ Crack in outer ring of Double-Row Cylindrical Roller Bearing</p>  <p>(A-6626)</p> <p>● Chip in outer ring rib of Cylindrical Roller Bearing</p>  <p>(A-6555)</p> <p>● Chip in outer ring rib of Cylindrical Roller Bearing</p>  <p>(A-6658)</p> |
| Causes | <p>■ Cracks</p> <ol style="list-style-type: none"> 1) Heavy load. 2) Excessively heavy internal load caused by improper installation. 3) Excessive interference at fitting, or shaft and housing of improper shape. 4) Instantaneous heat generation of bearing caused by sudden sliding at rolling surface, sliding surface or fitting surface. 5) Abnormal heat is generated due to shortage of lubricant. <p>● Chips</p> <ol style="list-style-type: none"> 1) Abnormally heavy axial load or impact load. 2) Partial impact of hammer or other tool used when bearing is mounting or dismounting. | |
| Countermeasures | <p>■ Cracks</p> <ol style="list-style-type: none"> a) Investigation followed by countermeasures for excessively heavy load. b) Removal of thermal impact. c) Improvement of interference (decrease of interference.) <p>● Chips</p> <ol style="list-style-type: none"> a) Improvement of mounting and dismounting procedures. b) Improvement of handling method. c) Investigation followed by countermeasures for excessively heavy load. | |

4 Brinelling and Nicks

| | Phenomena, causes and countermeasures | Examples of failures |
|-----------------|--|---|
| Phenomena | <ul style="list-style-type: none"> ■ Brinelling is depressions created on the part of the raceway surface which comes into contact with the rolling element, and is due to plastic deformation. Brinelling is also small depressions on the rolling surface caused by contamination by solid foreign matters. ● Nicks are a flaw caused by the direct impact received when bearings are hit by a hammer or other solid tool. | <ul style="list-style-type: none"> ■ Brinelling on outer ring raceway surface of Deep Groove Ball Bearing  (A-6474) ■ Brinelling on inner ring raceway surface of Tapered Roller Bearing  (A-6617) |
| Causes | <ul style="list-style-type: none"> ■ Brinelling <ol style="list-style-type: none"> 1) Extremely heavy load (static load, impact load) applied to bearing. 2) Solid foreign matter caught in bearing parts. ● Nicks <ol style="list-style-type: none"> 1) Faulty bearing mounting or dismounting. 2) Mis-handling of bearings. | |
| Countermeasures | <ul style="list-style-type: none"> ■ Brinelling <ol style="list-style-type: none"> a) Investigation followed by countermeasures for excessively heavy load or impact. b) Enhancement of sealing capability. c) Careful washing of shaft and housing to remove foreign matter. d) Filtering of oil. e) Investigation of flaking in target bearing together with other bearings. ● Nicks <ol style="list-style-type: none"> a) Improvement of bearing mounting and dismounting. b) Improvement of bearing handling. | |



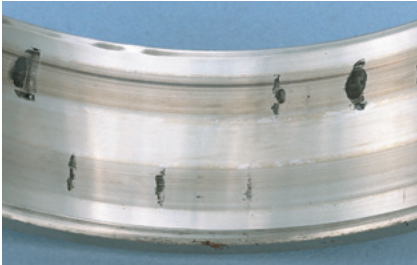
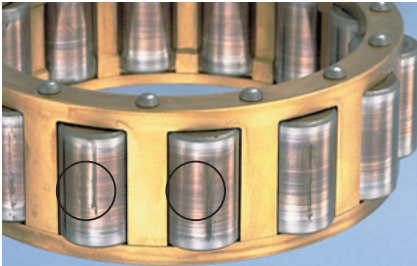
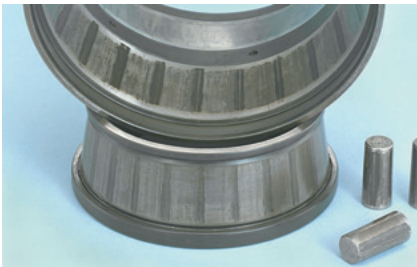
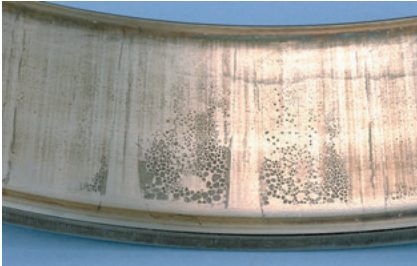

5 Scratches and Scuffing

| | Phenomena, causes and countermeasures | Examples of failures |
|-----------------|--|---|
| Phenomena | <ul style="list-style-type: none"> ■ A scratch is a relatively shallow flaw caused by sliding contact. ● Scuffing is a flaw caused by high contact pressure and heat on the rolling surface. In general, more serious scratches are regarded as scuffing. <ol style="list-style-type: none"> 1) Flaw in the axial direction (flaw occurring in mounting) <p>In the mounting of bearings whose outer rings and inner rings are separable, a flaw in the axial direction is sometimes caused by contact with the edge of rollers or raceway surfaces. These are referred to as flaws in the axial direction.</p> 2) Scuffing on roller end face and rib face <p>Cycloidal flaws can occur on the roller end or rib face of the bearing ring, which guides rollers. Flaws such as scratches, which occur on these parts are called scuffing.</p> | <ul style="list-style-type: none"> ■ Scratch on roller rolling surface of Cylindrical Roller Bearing  (A-6451, 6453) ■ Scratch on roller rolling surface of Cylindrical Roller Bearing <p>Scratch occurring in circumference direction.</p>  (A-6452) |
| Causes | <ol style="list-style-type: none"> 1) Flaw generated during mounting. <ol style="list-style-type: none"> a) Careless handling in mounting or dismounting. 2) Scuffing on roller end face and rib face. <ol style="list-style-type: none"> a) Improper lubrication at contact face. b) Excessive preload. c) Intrusion of foreign matter. d) Abnormal axial load. 3) Scratches and scuffing on raceway surface and rolling surface. <ol style="list-style-type: none"> a) Improper rotation of rolling element. b) Improper lubrication. c) Intrusion of foreign matter. | <ul style="list-style-type: none"> ■ Scratch on outer ring raceway surface of Double-Row Cylindrical Roller Bearing <p>Roller which slides when running.</p>  (A-6470) ● Scuffing on inner ring bore surface of Tapered Roller Bearing  (A-6736) |
| Countermeasures | <ol style="list-style-type: none"> 1) Flaw generated during mounting. <ol style="list-style-type: none"> a) Improvement in operations involved in mounting and dismounting. (Implementation of accurate center adjustment.) 2) Scuffing on roller end face and rib face. <ol style="list-style-type: none"> a) Review and improvement of lubricant and lubrication method. b) Inspection and countermeasures for abnormal load. c) Enhancement of sealing capability. 3) Scratches and scuffing on raceway surface and rolling surface. <ol style="list-style-type: none"> a) Review and improvement of lubricant and lubrication method. b) Enhancement of sealing capability. c) Sufficient cleaning of shaft and housing. | <ul style="list-style-type: none"> ● Scuffing on inner ring rib face and roller and face of Cylindrical Roller Bearing with rib  (A-6669) |



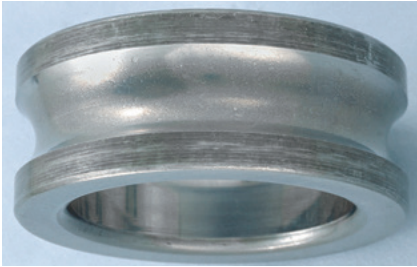

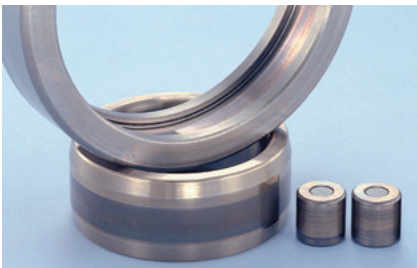
6 Rust and Corrosion

| | Phenomena, causes and countermeasures | Examples of failures |
|-----------------|---|--|
| Phenomena | <p>■ Rust is a film of oxide, hydroxide, or carbonate produced on a metallic surface by chemical action.</p> <p>● Corrosion is the phenomena of oxidation or dissolution occurring on the surface and is produced by chemical action (electric chemical action including combination or cell restructuring) with acid or alkali.</p> | <p>■ Rust on outer ring raceway surface of Double-Row Angular Ball Bearing Rust on raceway surface of one row.</p>  <p>(A-6494)</p> <p>■ Rust on outer ring raceway surface of Double-Row Cylindrical Roller Bearing Rust on roller pitch.</p>  <p>(A-6472)</p> |
| Causes | <p>■ Rust</p> <p>1) When equipment is stopped and its temperature decreases to the dew point, humidity in the housing turns into drops of water. The water drops often contaminate the lubricant. As a result, rust is generated on the bearing surface.</p> <p>2) When bearings are stored in a humid place for a long time, rust is generated on the raceway surface at intervals equal to the rolling elements spacing.</p> <p>● Corrosion</p> <p>1) Corrosion occurs when a sulfur or chlorine compound contained in lubricant additives decomposes under high temperature.</p> <p>2) Corrosion occurs when water gets inside bearings.</p> | <p>■ Rust on roller rolling surface of Cylindrical Roller Bearing Rust at one position the rollers.</p>  <p>(A-6479)</p> <p>■ Rust on inner and outer rings and on roller of Tapered Roller Bearing Rust on roller pitch of one row.</p>  <p>(A-7130)</p> |
| Countermeasures | <p>■ Rust</p> <p>● Corrosion</p> <p>a) Enhancement of sealing capability.</p> <p>b) Periodic inspection of lubricant.</p> <p>c) Provision for adequate rust prevention during storage of bearings.</p> | <p>■ Rust on outer ring raceway surface of Tapered Roller Bearing</p>  <p>(A-7051)</p> |



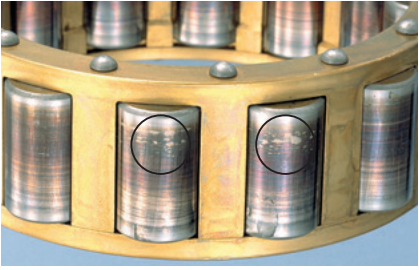

7 Pear skin, Discoloration

| Phenomena, causes and countermeasures | | Examples of failures |
|---------------------------------------|--|--|
| Phenomena | <p>■ Pear skin is a condition of the rolling surface where small depressions are created entirely as a result of many foreign matters being caught between parts. A rolling surface suffering from pear skin appears dim and is rough in texture. In the worst case, the surface is discolored by heat.</p> <p>● Discoloration is a phenomena in which the bearing surface is discolored by staining or heat generated during operation.</p> | <p>■ Pear skin on inner ring raceway surface of Double-Row Cylindrical Roller Bearing</p>  <p>(A-6556)</p> <p>■ Pear skin on inner ring raceway surface of Deep Groove Ball Bearing</p>  <p>(A-6560)</p> <p>● Discoloration on ball surface of Deep Groove Ball Bearing</p>  <p>(A-6639)</p> <p>● Discoloration on raceway surface, roller rolling surface of Cylindrical Roller Bearing</p>  <p>(A-6725)</p> <p>● Discoloration on inner ring and roller of Tapered Roller Bearing Staining</p>  <p>(A-6982)</p> |
| Causes | <p>■ Pear skin</p> <p>Since pear skin is mainly caused by contamination by foreign matter or lack of lubricant, these two points should be inspected most carefully.</p> <p>● Discoloration</p> <p>1) Discoloration (staining) is caused by deterioration of the lubricant or adhesion of colored substances to the bearing surface. Some of these substances can be removed by scrubbing or wiping with a solvent.</p> <p>2) A brown discoloration of the rolling or sliding surface is caused by adhesion of acidic powders generated by abrasion during operation. In general, these powders adhere uniformly to the bearing circumference.</p> | |
| Countermeasures | <p>■ Pear skin</p> <p>a) Careful washing of shaft and housing. b) Enhancement of sealing capability. c) Filtering of oil. d) Review of lubricant and lubrication method.</p> <p>● Discoloration</p> <p>Discoloration can be classified as follows: staining, electric pitting, rust, corrosion, and temper color. Stains can be removed by wiping with an organic solvent (acetone). When observed by microscope, electric pitting is small depressions caused by electric discharge. If unevenness remains on the surface after wiping with sand paper, the phenomena are judged to be rust and corrosion. If unevenness is completely removed, the phenomena is judged to be temper color caused by heat.</p> <p>a) Improvement of heat dissipation from bearings. b) Improvement of lubrication. c) Review followed by countermeasures for bearing operating conditions.</p> | |

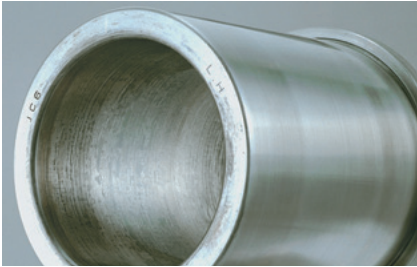

8 Smearing

| | Phenomena, causes and countermeasures | Examples of failures |
|-----------------|--|---|
| Phenomena | <p>■ Smearing is a phenomena where minute seizure is concentrated on the rolling surface. In smearing, the surface is partially melted by heat of high temperature generated by friction; and on some parts, the surface damaged becomes significantly rough.</p> | <p>■ Smearing on inner ring raceway surface of Deep Groove Ball Bearing</p>  <p>(A-6640)</p> <p>■ Smearing on ball surface</p>  <p>(A-6641)</p> |
| Causes | <p>1) Smearing occurs if the oil film disappears as rolling elements stop rotating due to inappropriate use or improper lubrication, and then start to slide on the raceway surface.</p> <p>2) In ball bearings, smearing is caused by sliding or spinning of balls; and, in roller bearings, smearing tends to occur when the roller enters into on from the load zone.</p> | <p>■ Smearing on inner ring raceway surface of Angular Ball Bearing</p>  <p>(A-6642)</p> <p>■ Smearing on outer ring raceway surface of Cylindrical Roller Bearing</p>  <p>(A-7435)</p> |
| Countermeasures | <p>a) Review followed by countermeasures to improve the formation of oil film.</p> <p>b) Provision for extreme-pressure lubricant.</p> <p>c) Adoption of countermeasures to prevent sliding. (by diminishing mounting clearance.)</p> | <p>■ Smearing on roller rolling surface of Cylindrical Roller Bearing</p>  <p>(A-6480)</p> |

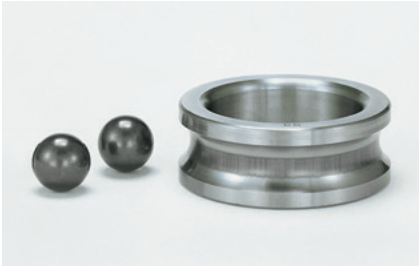
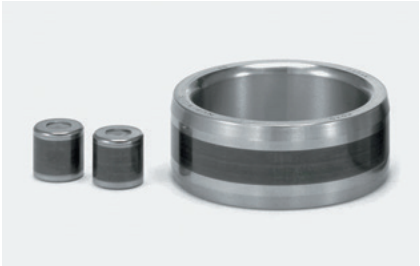
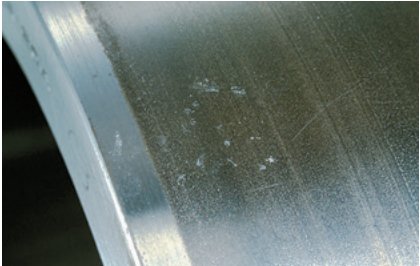
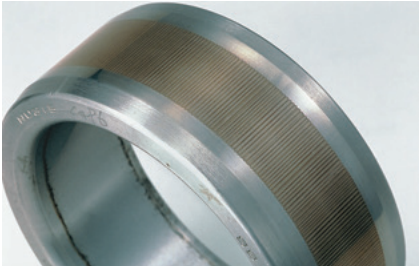

9 Creep

| Phenomena, causes and countermeasures | | Examples of failures |
|---------------------------------------|--|--|
| Phenomena | <p>■ Creep is the displacement during operation of a bearing ring, relative to the shaft or housing.</p> | <p>■ Creep of Deep Groove Ball Bearing inner ring</p>  <p>(A-6726)</p> <p>■ Creep of Deep Groove Ball Bearing outer ring</p>  <p>(A-6957)</p> <p>■ Creep of Double-Row Cylindrical Roller Bearing inner ring</p>  <p>(A-6647)</p> <p>■ Creep of Tapered Roller Bearing inner ring</p>  <p>(A-6616)</p> |
| Causes | <p>Creep occurs when interference is too small in relation to the heat or load generated during operation.</p> | |
| Countermeasures | <p>Review of interference between inner ring and shaft and between outer ring and housing. (Increase of interference.)</p> | |

10 Electric pitting

| | Phenomena, causes and countermeasures | Examples of failures |
|---|--|--|
| <p style="writing-mode: vertical-rl; transform: rotate(180deg);">Phenomena</p> | <p>■ Electric pitting is a phenomena in which the bearing surface is partially melted by sparks generated when electric current enters the bearing and passes through an extremely thin oil film at the rolling contact point. Electric pitting can be classified into pitting or ridge marks, which the rolling contact surface propagates. Depressions like craters can be observed when pitting is magnified, indicating that the surface has been melted by sparks.</p> <ul style="list-style-type: none"> • Significant electric pitting causes flaking. <p>In addition, since the hardness of the rolling contact surface deteriorates, the surface tends to be easily worn.</p> <ul style="list-style-type: none"> • If a fluting surface is found by manual inspection, or pitting is observed by normal visual inspection, the bearing cannot be re-used. | <p>■ Electric pitting on Deep Groove Ball Bearing Fluting on inner ring raceway surface.</p>  <p style="text-align: right;">(A-6652)</p> <p>■ Electric pitting on Cylindrical Roller Bearing</p>  <p style="text-align: right;">(A-6653)</p> |
| <p style="writing-mode: vertical-rl; transform: rotate(180deg);">Causes</p> | <p>Bearing surface is partially melted by electric current passing through the bearing.</p> | <p>■ Electric pitting on Cylindrical Roller Bearing inner ring</p>  <p style="text-align: right;">(A-5180)</p> <p>■ Fluting on Cylindrical Roller Bearing inner ring</p>  <p style="text-align: right;">(A-6651)</p> |
| <p style="writing-mode: vertical-rl; transform: rotate(180deg);">Countermeasures</p> | <p>a) Improvement of grounding or improvement of grounding maintenance. b) Provision of insulation for bearings or for the section near bearings.</p> | <p>■ Fluting on Spherical Roller Rolling surface</p>  <p style="text-align: right;">(A-6409, 6650)</p> |

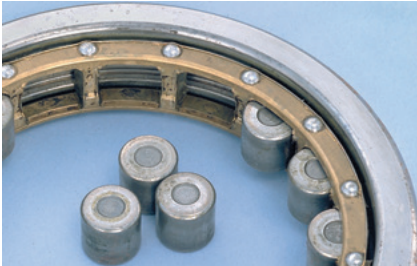
11 Seizure

| Phenomena, causes and countermeasures | | Examples of failures |
|---------------------------------------|--|--|
| Phenomena | <p>■ Although scuffing and smearing can be categorized as seizure, scuffing is generally regarded as a more serious type of failure. The seizure described in this section is the kind in which bearing parts are melted and adhere to one another due to abnormal heat or the rolling surface becoming rough; as a result, the bearing can no longer rotate.</p> <p>• Once seizure occurs, the bearing cannot be used again because the hardness has deteriorated and smooth rotation is impossible on the rough surface.</p> | <p>■ Seizure of Cylindrical Roller Bearing Rollers are removed because pocket surface of cage has become worn.</p>  <p>(A-6457)</p> <p>■ Seizure of Cylindrical Roller Bearing with rib</p>  <p>(A-6464)</p> <p>■ Seizure of Tapered Roller Bearing Heat is generated on roller end face and inner ring rib face.</p>  <p>(A-6679)</p> |
| Causes | <p>Seizure results from abnormal heat generated by improper lubrication, excessive preload, or improper contact of rolling elements with the raceway surface, which cannot be compensated for by the cooling method or lubrication employed in the bearings.</p> | |
| Countermeasures | <p>Causes should be investigated; and appropriate countermeasures corresponding to the results should be taken.</p> | |

12 Failure of Cage

| | Phenomena, causes and countermeasures | Examples of failures |
|----------------------------|---|---|
| Phenomena | <ol style="list-style-type: none"> 1) Cracks and Chips If a seriously cracked bearing is used under heavy operating conditions, it will fail. 2) Flaw and Distortion <ul style="list-style-type: none"> • Since cages are made from soft material, they tend to be damaged or become distorted by external forces or from contact with other parts. • Since cages with a serious flaw also have distortion, their accuracy may decrease. <p>And the motion of the rolling element is consequently affected; therefore, especially the size and location of the flaw should be checked with care.</p> 3) Rust and Corrosion If rust or corrosion is found on cages, it can be assumed that it is also occurring on the bearing ring and rolling element. 4) Wear As described in Section 2, cages under the following conditions can no longer be used because proper rotation of the rolling element is hindered: cages whose pocket surface has been worn down in the shape of the rolling elements; cages which cannot maintain the rolling elements, and cages whose guide surface for the bearing ring has been eccentrically or severely worn. 5) Looseness and Improper Riveting Looseness of the rivet is caused by an error in bearing mounting, moment load, variable load, vibration, etc. If a bearing is operated with improper riveting, the bearing cannot be returned to service because the rivets may break. | <ul style="list-style-type: none"> ● Crack of Deep Groove Ball Bearing cage  (A-6455) ● Crack of Tapered Roller Bearing cage  (A-6670) ● Distortion of Cylindrical Roller Bearing cage  (A-7026) |
| Causes and countermeasures | <ol style="list-style-type: none"> 1) Cracks and Chips <ol style="list-style-type: none"> a) Careless handling. b) Abnormal load, Vibration impact. 2) Flaw, Distortion <ol style="list-style-type: none"> a) Careless handling. 3) Rust, Corrosion <ol style="list-style-type: none"> a) Improvement of sealing capability. Periodic inspection of lubricant. b) Provision of adequate rust prevention during storage of bearings 4) Wear <ol style="list-style-type: none"> a) Improper lubricant or shortage of lubricant... Investigation followed by countermeasures involving lubricant and lubrication method. b) Contamination by foreign matter...Improvement of sealing capability. 5) Looseness and Cut-Off of Rivet <ol style="list-style-type: none"> a) Improper bearing mounting...Reduction of bearing inclination. b) Severe load or vibration...Consultation with Koyo. | <ul style="list-style-type: none"> ● Looseness of Cylindrical Roller Bearing cage rivet  (A-6481) ● Rust on Tapered Roller bearing cage  (A-7131) |

JTEKT Corporation WEB site

<https://www.jtekt.co.jp/e/>



JTEKT Bearing WEB site

<https://koyo.jtekt.co.jp/en/>



JTEKT Overseas hubs

<https://www.jtekt.co.jp/e/company/global.html>





ONE! JTEKT

Koyo, TOYODA, and JTEKT
unified all brands into JTEKT.

JTEKT | JTEKT CORPORATION

www.jtekt.co.jp

☆ The contents of this catalog are subject to change without prior notice. Every possible effort has been made to ensure that the data herein is correct; however, JTEKT cannot assume responsibility for any errors or omissions.

**Reproduction of this catalog without
written consent is strictly prohibited.**

CAT.NO.WS001EN-ODS
Printed in Japan '24.03 ('92.4)